

Kodak Mercury T-HD Plate Processors

Technical Specifications

	Mercury T-HD 850	Mercury T-HD 1250	Mercury T-HD 1550
Accredited digital plates	Kodak Electra Excel Thermal Plates, Kodak Electra XD Thermal Plates, Kodak Thermal Platinum Digital Plates and Kodak Thermal Gold Digital Plates		
Suitability	Recommended for processing over 10,000 m ² per year		
Maximum plate width	850 mm (33.5")	1250 mm (49.2")	1550 mm (61.0")
Minimum plate length, with center rollers	320 mm (12.6")	320 mm (12.6")	320 mm (12.6")
Plate gauge	0.15 - 0.50 mm (.006 - .020")	0.15 - 0.50 mm (.006 - .020")	0.15 - 0.50 mm (.006 - .020")
Adjustable temperature, developer	15°C - 32°C (59°F - 89.6°F)	15°C - 32°C (59°F - 89.6°F)	15°C - 32°C (59°F - 89.6°F)
Adjustable temperature, dryer	0 - 100%	0 - 100%	0 - 100%
Tank volume, pre-wash	N/A	N/A	N/A
Tank volume, developer, with center rollers	43 liters (11.4 US gal)	65 liters (17.2 US gal)	80 liters (21.1 US gal)
Tank volume, wash	33 liters (8.7 US gal)	48 liters (12.7 US gal)	60 liters (15.9 US gal)
Tank volume, gum	5 liters (1.3 US gal)	6.5 liters (1.7 US gal)	8 liters (2.1 US gal)
Water supply	Tap water, min 1.4 bar	Tap water, min 1.4 bar	Tap water, min 1.4 bar
Pre-wash/wash	Tap water or recirculation	Tap water or recirculation	Tap water or recirculation
Water consumption	15 l/min (4 US gal/min)	20 l/min (5.3 US gal/min)	25 l/min (6.6 US gal/min)
Processing speed	60 - 200 cm/min (23.6 - 78.7")	60 - 200 cm/min (23.6 - 78.7")	60 - 200 cm/min (23.6 - 78.7")
Level control	Yes	Yes	Yes
Power	50 - 60Hz, 200 - 230V, 1/2-phase. Consumption < 3.0 kWh at 230V		
Approvals	Carries CE Marking and is ETL Listed for the United States and Canada		
Weight, uncrated	585 kg (1,290 lb)	735 kg (1,620 lb)	795 kg (1,753 lb)
Weight, crated	635 kg (1,400 lb)	785 kg (1,731 lb)	845 kg (1,863 lb)

VLF option available. Details upon request.



Kodak
Mercury
T-HD Plate Processors

System Schematics

Dimensions	A	B	C	D
Mercury T-HD 850	1423 mm (56")	950 mm (37.4")	990 mm (39")	3070 mm (120.9")
Mercury T-HD 1250	1823 mm (71.8")	1350 mm (53.1")	1440 mm (56.7")	3520 mm (138.6")
Mercury T-HD 1550	2123 mm (83.6")	1650 mm (65")	1890 mm (74.4")	3970 mm (156.3")

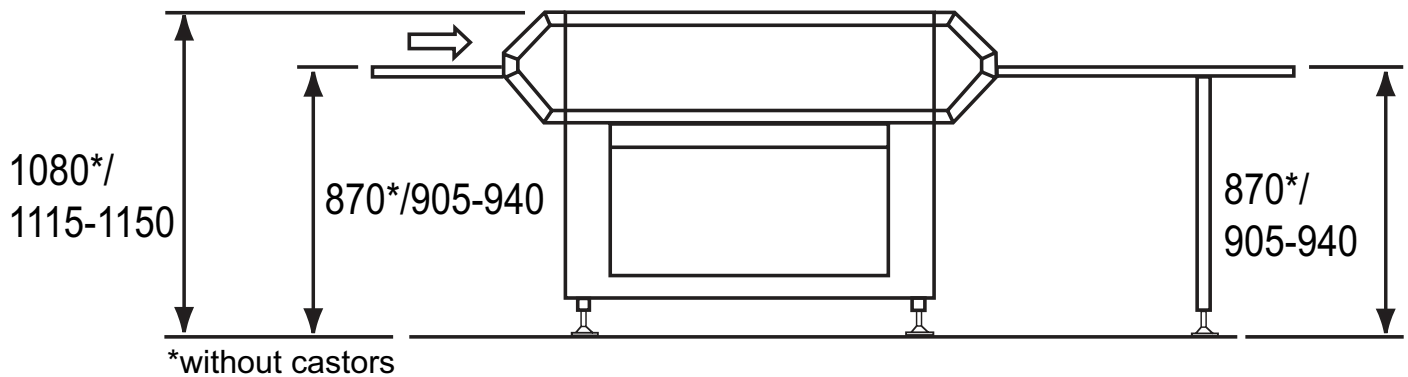
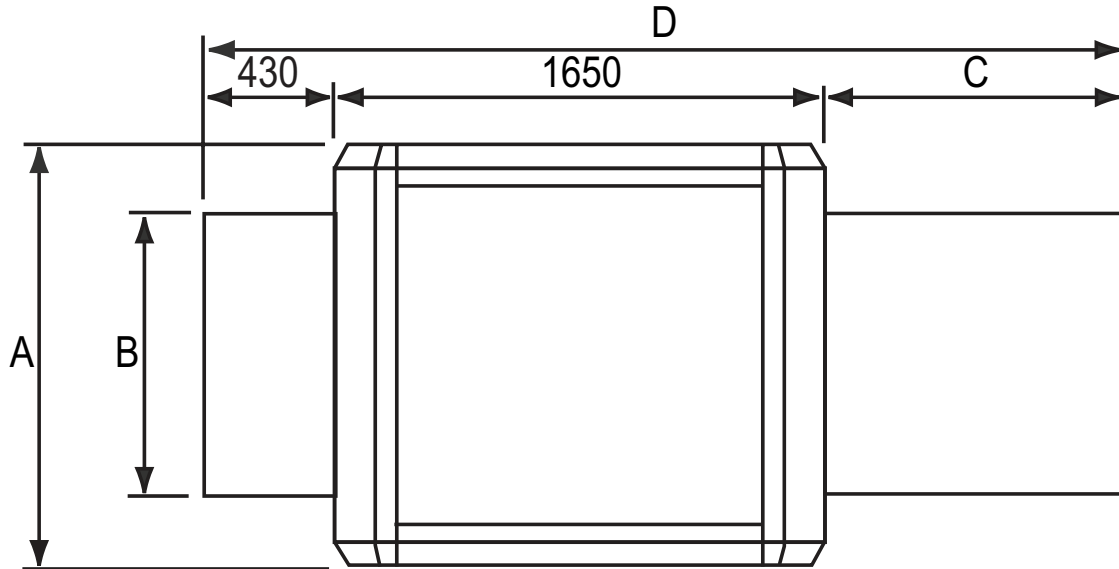

Infeed table and exit table C are options and need to be ordered separately.

To learn more about solutions from Kodak:

Visit graphics.kodak.com

Produced using **Kodak** Technology.

Eastman Kodak Company
343 State Street
Rochester, NY 14650 USA

©Kodak, 2009. Kodak, Electra, Electra Excel, Mercury, Thermal Gold and Thermal Platinum are trademarks of Kodak.

Subject to technical change without notice.

W.PC.854.0409.en.04